

55" ULTRA NARROW BEZEL LED VIDEO WALL MONITOR



VZ-55UNBS ADVANTAGES

- 55" 1080p CCTV LED Monitor
- Ultra Narrow **1.2 mm** Metal Bezel
- Supports 4K (3840x2160) Resolution
- Supports HDMI (2.0), DVI-D, DP, VGA
- Supports Serial Control Software
- Daisy Chain System - HDMI up to 15 x 15
- Auto Source & Power Recovery
- Frame Comp Function
- Mullion Compensation Applied
- Advanced Heat Management
- Digital / Analog Inputs
- 3D Comb-Filter & High Contrast
- 3-Year Warranty



MODEL #		VZ-55UNBS
VIDEO		
Screen Size	49"	
Max. Resolution	1920 x 1080 @60Hz	
Pixel Pitch	0.630 mm x 0.630 mm	
Brightness	500cd/m ² (Typical)	
Contrast Ratio	5000:1	
Aspect Ratio	16 : 9	
Viewing Angle (H/V)	178° / 178°	
Display Color	16.7M	
Response Time	< 8ms	
Active Display area (H x V)	1209.6 mm x 680.4 mm	
INTERFACE		
VGA In (15Pin D-Sub)	1	
DP In	1	
DVI-D In	1	
HDMI In / Out	1 / 1	
USB In (Upgrade)	1	
RS-232 (RJ-45) In	1 (Serial Control / IR Receiver)	
RS-232 (RJ-45) Out	2 (Serial Control)	
Audio Out	1	
SPECIAL FEATURES		
Bezel Width	TOP and LEFT Side	0.096" / 2.3 mm
	BOTTOM and RIGHT Side	0.053" / 1.2 mm
	ACTIVE AREA to ACTIVE AREA	0.149" / 3.5 mm
Advanced Anti-Image Residual Correlation	Support	
3D Comb-Filter	Support	
Language	English, Spanish, French and Portuguese	
SUPPORT RESOLUTION		
HDMI (2.0) In / Out	3840 x 2160 @ 60Hz	
DP In	3840 x 2160 @ 30Hz	
DVI-D In	3840 x 2160 @ 30Hz	
VGA In	1920 x 1080 @ 75Hz	

DIMENSIONS & WEIGHT		
Outline Dimension (W x H x D)	47.77" x 26.93" x 4.55" (1213.4 mm x 684.2 mm x 115.6 mm)	
Net Weight / Gross Weight	66.91 lb (30.35 kg) / 83.77 lb (38.0 kg)	
MOUNT		
Universal	600 x (100 x 4) mm, M6 x 12 Screws	
GENERAL		
Transmitter - IR Remote Control	YES	
Power	Electrical Ratings	AC100 ~ 240V (50/60Hz)
	Consumption	180 W (Max) / 2W (Standby)
Regulations	FCC, RoHS	
Warranty	Parts/ Labor	3 Year / 3 Year
Operating Temperature	32 - 122°F / 0 - 50°C	
Storage Temperature	32 - 140°F / 0 - 60°C	
Operating Humidity (Non-Condensing)	20% ~ 80% RH	
Compatible Mounts	Wall	VZ-XM55, VZ-WM71
	Ceiling	VZ-CMK04, VZ-CMKIT-04
Accessories	AC110V Power Cable x 1, HDMI Cable x 1, Manual x1, CAT5 Cable (RS232) x 1, Remote Controller x 1, IR Receiver x 1, Converter (RJ45 to RS232) x 1	

Contact ViewZ

- Address : 177 W. Orangethorpe Ave., Placentia, CA 92870
- Phone : (714) 996-1177, Fax : (714) 996-1138
- Sales : sales@viewzusa.com
- Specification subject to change without notice.

DAISY CHAIN

Up to 15 x 15

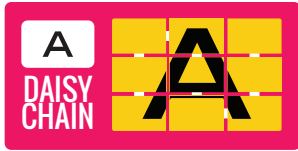

1080p input will be shown as 1080p via whole monitors

4K input will be shown as 4K via whole monitors

4K Source Input



HDMI Cable

HDMI CABLE

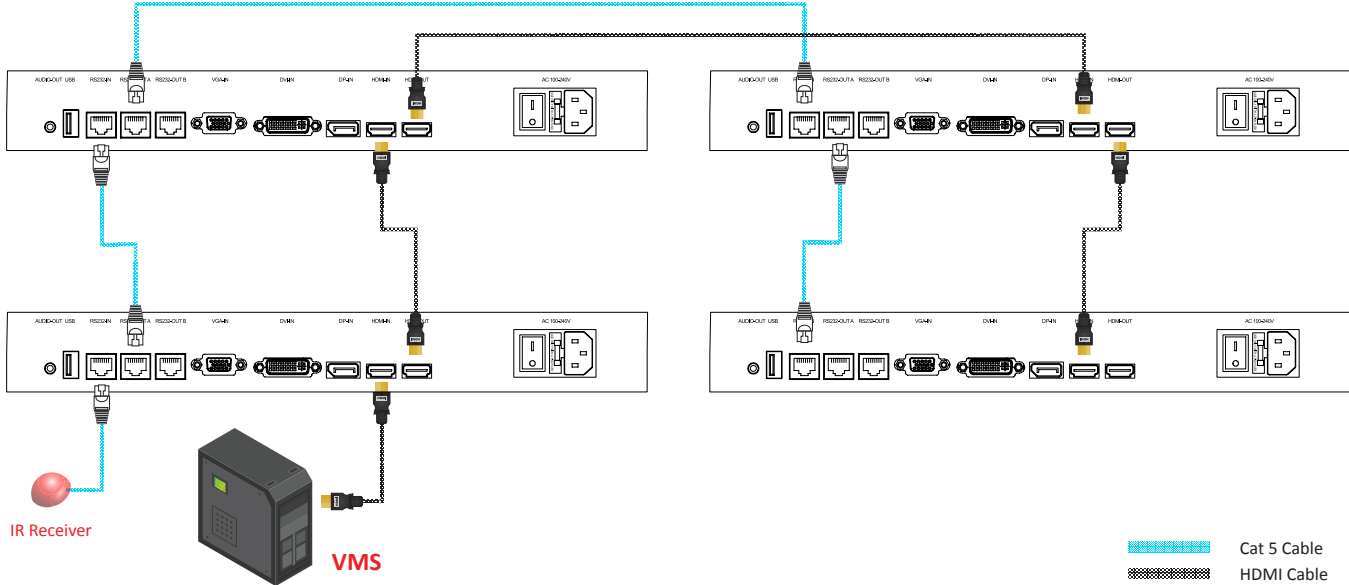

Contact ViewZ

- Address : 177 W. Orangethorpe Ave., Placentia, CA 92870
- Phone : (714) 996-1177, Fax : (714) 996-1138
- Sales : sales@viewzusa.com
- Specification subject to change without notice.

DIMENSIONS

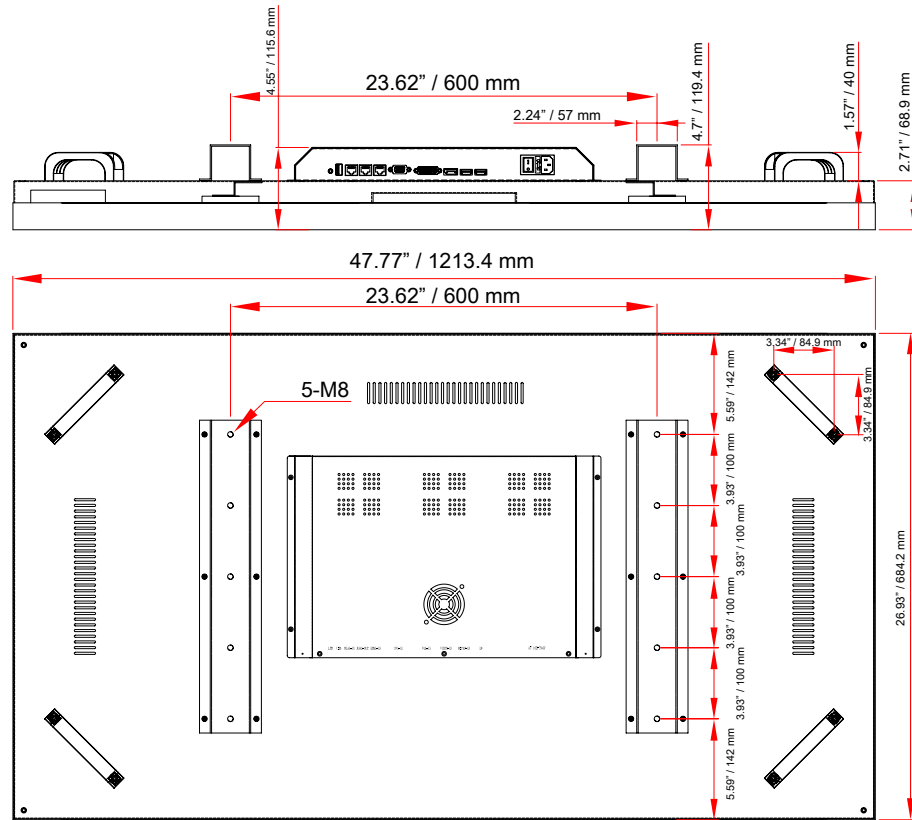

INTERFACE

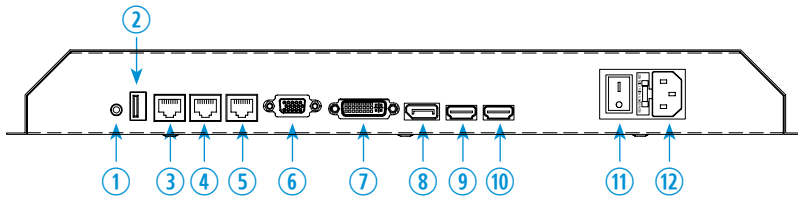

1. AUDIO OUT
2. USB
3. RS232 (RJ-45) IN
4. RS232 (RJ-45) OUT - A
5. RS232 (RJ-45) OUT - B
6. VGA IN
7. DVI-D IN
8. DP IN
9. HDMI IN
10. HDMI OUT
11. ON / OFF Switch
12. AC 100-240V IN

Contact ViewZ

- Address : 177 W. Orangethorpe Ave., Placentia, CA 92870
- Phone : (714) 996-1177, Fax : (714) 996-1138
- Sales : sales@viewzusa.com
- Specification subject to change without notice.