

49 inch DUAL QHD 32:9 Curved SECURITY MONITOR



**USB TYPE C
VIDEO & 65W PD**

VZ-49CGM ADVANTAGES

- 49" Curved LED Panel
- Supports Dual QHD (5120x1440) Resolution
- Ultrawide 3800R Curved Screen
- High Response Time - 1ms / Support MPRT
- Supported Display Port (1.4) In 1, HDMI (2.1) In x1, Audio Out x1
- USB (Type C - Video & 65W PD) x1, USB (Type B) x 1, USB (Type A) x 4
- Supports HDCP 2.3
- Supports PIP / PBP
- A built-in Anti-Flicker Free Function
- Tilt 5° ~ -15°, Swivel ± 45° and Height Adjustment 5.9" (150 mm)
- Wide Viewing Angle (IPS Panel)

3800R Curved

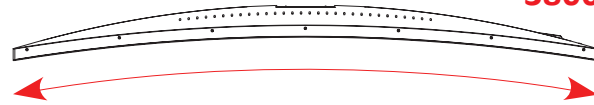

| MODEL # | VZ-49CGM | |
|-------------------------------------|--------------------------------|--|
| PANEL | | |
| Screen Size | 49" | |
| Max. Resolution | 5120 x 1440 @60Hz | |
| Pixel Pitch | 0.234 x 0.234 mm | |
| Brightness | 350cd/m ² (Typical) | |
| Contrast Ratio | 1000:1 | |
| Aspect Ratio | 32 : 9 | |
| Viewing Angle (H/V) | 178° / 178° | |
| Display Color | 1.07 B | |
| Response Time | < 8 ms / MPRT 1 ms | |
| INTERFACE | | |
| Display Port (1.4) In | 1 | |
| HDMI (2.1) In | 1 | |
| USB (Type C - Video & 65W PD) In | 1 | |
| USB (Type B) In | 1 | |
| USB (Type A) In | 4 | |
| Audio Out | 1 | |
| AUDIO | | |
| Built in speaker | 2W x 2 | |
| SPECIAL FEATURES | | |
| Flicker Free | Support | |
| MPRT (Moving Picture Response Time) | Support | |
| Over Drive | Support | |
| Blue Light Filter | Support | |
| HDR | Support | |
| PIP / PBP | Support | |
| SUPPORT RESOLUTION | | |
| Display Port (1.4) In | 5120 x 1440 @ 60Hz | |
| USB (Type C) In ¹ | 5120 x 1440 @ 60Hz | |
| HDMI (2.1) In | 5120 x 1440 @ 60Hz | |

| DIMENSIONS & WEIGHT | | |
|---|---|--|
| Outline Dimension (W x H x D) - without stand | 47.84 x 14.4 x 4.56" / 1215.2 x 365.8 x 115.9 mm | |
| - with stand | 47.84 x 22.32 x 12.02" / 1217 x 567.1 x 305.5 mm | |
| Net Weight / Gross Weight | 25.35 lbs (11.5 kg) / 33.95 lbs (15.4 kg) | |
| MOUNT | | |
| VESA | 100 x 100 mm (M4) | |
| GENERAL | | |
| Power | Electrical Ratings Consumption | DC 24V (AC100 ~ 240V (50/60Hz)) / 3A ≤ 62 W / 0.5 W (Stand-by) |
| Regulations | CE, FCC (A), RoHS | |
| Operating Temperature | 32 - 122°F / 0°C ~ 50°C | |
| Operating Humidity | 20 ~ 85% RH | |
| Language (OSD) | English | |
| Compatible Mounts | Wall Ceiling | VZ-WM50 VZ-CMKIT-01, VZ-CMKIT-02, VZ-CM308 |
| Accessories | Stand (1set), Manual (1pc), Power Adapter (1pc), DP Cable (1pc) | |

Contact ViewZ

- Address : 177 W. Orangethorpe Ave., Placentia, CA 92870
- Phone : (714) 996-1177, Fax : (714) 996-1138
- Sales : sales@viewzusa.com

DIMENSIONS

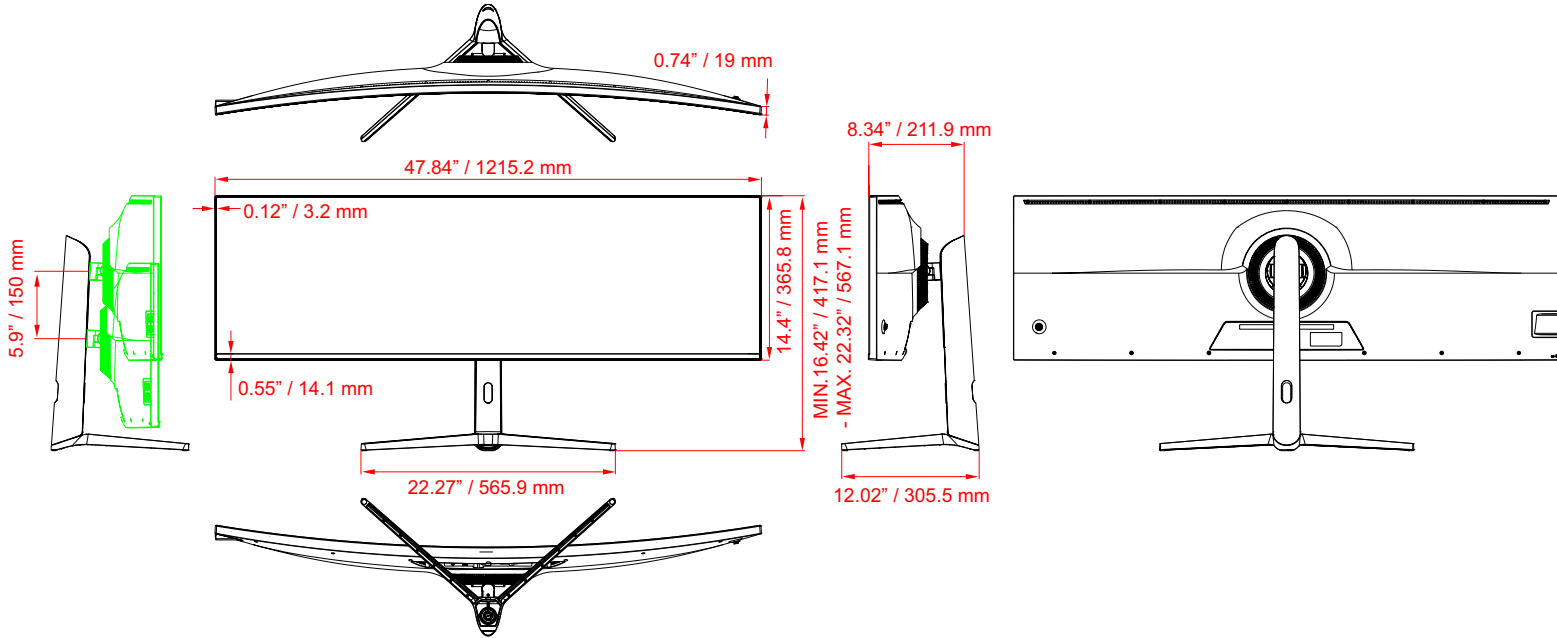

INTERFACE

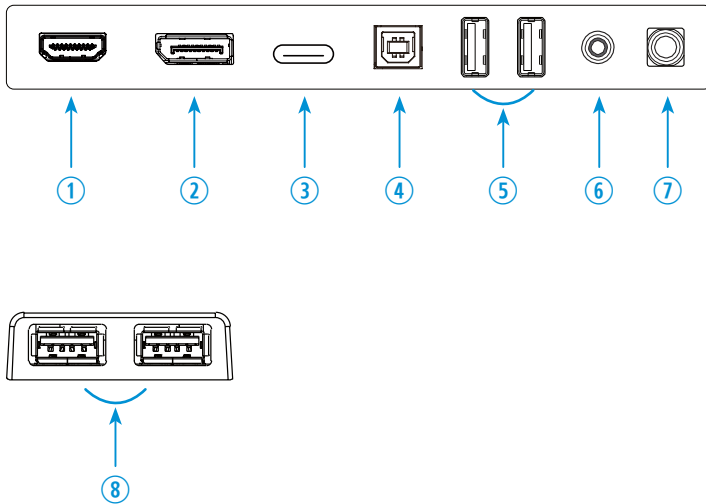

1. Display Port IN x1
2. HDMI IN x1
3. USB (Type C) x1
4. USB (Type B) x1
5. USB (Type A) x2
6. Audio OUT
7. DC 24V
8. USB (Type A) x2

Contact ViewZ

- Address : 177 W. Orangethorpe Ave., Placentia, CA 92870
- Phone : (714) 996-1177, Fax : (714) 996-1138
- Sales : sales@viewzusa.com